

Laboratorium Techniki Budowlanej
Sp. z o.o.
Dąbrowa Górnicza 41-306, ul. Laski 83
NIP 6292465943; KRS 0000447876
Jednostka notyfikowana/Notified body 1827
www.LTB.org.pl



tel/fax: (+48) 32 26 4 079 kom: 602 15 28 97; 608 50 66 35; 604 97 62 07
Bank Śląski S.A. o/Dąbrowa Górnicza nr 17 1050 1360 1000 0023 6773 9022

AB 661

Evidence of Type Testing (TT)
according to Standard EN 14351-1+A2
№ 520/B – 2017 – 5

Laboratorium Techniki Budowlanej used the calculation method, in accordance with Standard EN ISO 10077-1:2006 and EN ISO 10077-2:2012, to define the thermal insulation of windows

IV 92 Thermo (IV88)
system described in test report 520/B-2017, manufactured by:

„SŁOWIŃSCY” Sp. J.
62-400 Słupca, ul. Wspólna 2, Poland

Test's results		
Cross section	U_f [W/m ² K]	Ψ [W/mK]
Frame / Leaf	1,1	0,040
Frame with weather drip /Leaf	1,3	0,043
IGU	0,5	
U_w [W/m ² K] for window 1,23 x 1,48 m	0,82	
The results of the examination refer only to the tested sample and the test conditions. The parameters for other constructions should be declared in compliance with the provisions specified in standard EN 14351-1+A2.		

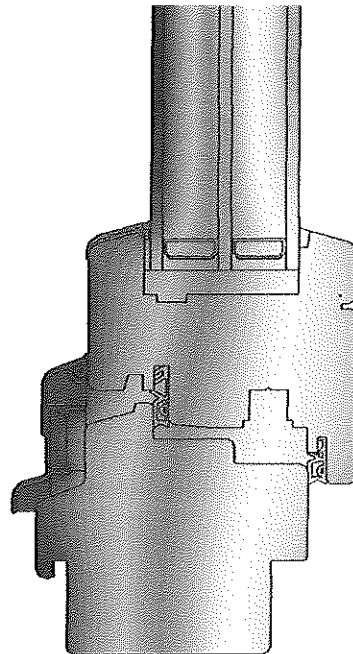

Quality Manager

Maciej Żyła
Maciej Żyła

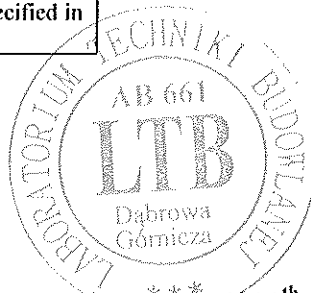

Engineering Manager

Bogdan Wójcisz
mgr inż. Bogdan Wójcisz

Dąbrowa Górnicza, *** dated 21th April 2017